

Technical description and instruction manual of an extended cavity diode laser ECDL-8550R (S/N 051330)

The extended cavity diode laser ECDL-8550R is a tunable source of high-coherent radiation in near infrared. The central wavelength of the working range is 852 nm. However, the detuning of 2 nm to short and long wavelengths is possible. The laser can be used in metrology, spectroscopy and interferometry.

ECDL-8550R consists of an optical head and an electronic unit connected by a cable via connectors DHS-15 (Fig.1 pos.8). The standard length of the cable is 1.8 m. The plug of the electronic unit must be inserted into the **earthed socket**. The optical head is grounded. However, it is necessary to remember that there is a high voltage (200V) supplying piezo-element under the lid of the optical unit. The piezo-element is accessible when the lid is taken off.

The optical head

The optical head (Fig.1) consists of

a mount (pos.2) holding the common module (pos.3) of an antireflection coated laser diode (LD) and a collimating objective ($N_A=0.48$; $f=4.5$ mm; output aperture – 4.3 mm);

a thermoelectric microcooler (Peltier element);

a thermosensor mounted into the ECDL housing just beneath the mount (10 kOhm thermistor);

a diffraction grating (pos.4) attached to a lever (pos.9);

a piezo element (pos.7) moving the lever.

The ECDL housing (pos.1) serves as a framework for all optical and mechanical components. To provide at the same time the tolerable thermo contact and the electrical isolation of the LD module in respect to the ECDL housing, the mount holding the common LD-objective module is fixed via a sapphire plate. A plastic lid protects an optical cavity from a dust, thermo and acoustic perturbations. The base of the optical head has longitudinal side slots to mount the head onto an optical table.

The optical cavity of the tunable laser is formed by the rear high-reflective facet of the laser diode and the Littrow diffraction grating (1800 grooves/mm). The grating is fastened to a horizontal shaft, which defines the proper direction of the laser beam diffraction. A piezo-element varies simultaneously the incidence angle of the laser beam and the cavity length. This allows extending the range of continuous tuning. The adjustment screw (pos.6) rotating the grating realizes the coarse tuning of the laser wavelength.

The precise matching of the wave reflected from a grating and the incident one is crucial for an extended cavity diode laser to obtain high coherence and significant output power at the same time. The ECDL-8550R does not have control knobs to adjust the position of the collimating objective in respect to the laser diode and to align the laser beam in vertical direction. All these important settings require serious skills, and they are made on an assembling stand in advance. In the case of laser diode degradation the common module of a laser diode and a collimating objective must be replaced as a unit.

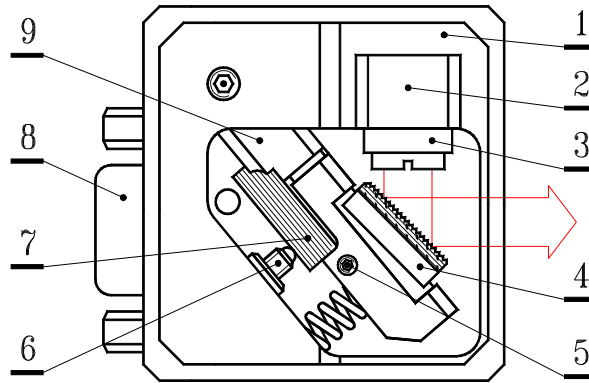

Fig.1. The optical head (top view, a lid is off). 1 – the ECDL housing; 2 – the mount of the common module; 3 – the common module of a laser diode and a collimating objective; 4 – the diffraction grating attached to the horizontal shaft; 5 – the vertical M2 lock-screw; 6 – the horizontal M3x0.25 tuning screw; 7 – the piezo-element; 8 – the connector DHS-15F; 9 – the tuning lever.

Contrary to the collimating objective the vertical alignment of the laser beam still remains possible even after demounting of the ECDL from the assembling stand. The horizontal axle (horizontal shaft) of the diffraction grating is gripped by a collet. The collet closes or opens when the vertical lock-screw (pos.5) is turned clockwise or counter-clockwise respectively. The slightly asymmetrical grip of the horizontal axle in the collet rotates the axle when the screw locks the collet. Typically clockwise rotation of the lock-screw moves the laser beam up; counter-clockwise rotation moves the beam down. **Do not rotate the lock-screw more than a quarter of a turn!** Otherwise it might be broken or the horizontal axle might be completely released. If more beam shift is necessary, then the Γ -shaped lever from the maintenance kit must be used. It can be inserted into the slot of the shaft butt-end and fixed by M2 screw. The horizontal shaft rotates freely when the lock-screw is loosened. One can tight the lock-screw after alignment taking into account the above mentioned axle rotation during tightening.

Typically the output beam of a laser diode is astigmatic. Therefore, sometimes the most effective optical feedback is achieved at the slightly convergent output beam, that is to say the inessential convergence ($\sim 2 \times 10^{-3}$) of a laser beam does not demonstrate the wrong alignment of the ECDL.

The electronic unit

The electronic unit (ULDC242 – the universal laser diode controller) controls the laser diode current, the temperature of the laser housing, and the length of an external part of the laser cavity with the accuracy sufficient to get the required output characteristics of the ECDL-8550R. The ULDC242 has two independent circuits for temperature control. Only one is activated with the presented model of an extended cavity DL.

An analog power supply provides all voltages essential for control circuits: stabilized $\pm 15V$, $+200V$, $\pm 5V$ and unstabilized $\pm 6V$. There are three fuse sockets under the unit lid close to the line connector. One socket corresponds to the line voltage of 240V AC, another one – to the voltage of 220V AC and third one – to 117V AC. **Only one fuse of 2A must be inserted into the relevant socket!** One more fuse of 100 mA (F1 from Fig. 6 and 12) protects the output of the high-voltage power supply from the abridgement. To open the unit lid unscrew four screws from the unit bottom.

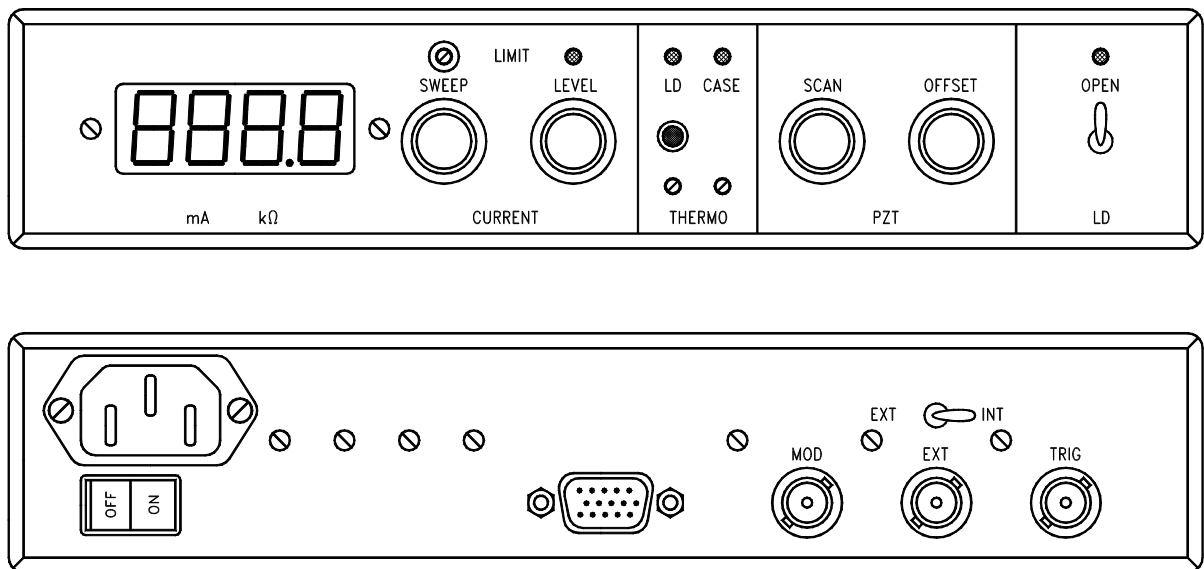

Fig.2. The front and rear panels of the electronic unit.

There are few functional zones on the front panel of the electronic unit reflecting operation of a current source (CURRENT), a temperature controller (THERMO), a high-voltage amplifier (PZT), and a laser diode shunt (LD) (Fig.2).

The CURRENT zone includes a digital monitor, control knobs of LD current level (LEVEL), scan amplitude (SWEEP), and current cut-off (LIMIT). A red light emitting diode (LED) is on in the case of current limitation. The maximum current value of the electronic unit (ULDC242) is 190 mA. The full scan amplitude of the current is about 50 mA.

The internal triangular-wave generator can modulate the LD current at line frequency and its sub-harmonics **f**, **f/2**, **f/4**, **f/8**. To set frequency of modulation, only one corresponding jumper of the DIP-8 switch on the printing board (SW5) must be set in position ON. Taking into account the low-frequency mechanical resonance of the laser cavity, the frequency **f/2** (that is 30 Hz for USA and 25 Hz for Europe) is preset in ECDL-8550R. The higher frequencies might be used, if the high sweep rate is important and the excess amplitude ripple in the vicinity of the extremum of the modulation signal can be neglected. The trimmer of current cut-off (LIMIT) is located above the SWEEP knob. Such a current limitation might be necessary to prevent degradation of a laser diode due to accidental current overload. The current overload indicator is located to the right from the corresponding trimmer.

The THERMO zone includes two trimmers of temperature adjustment for both (LD and CASE) loops of thermostabilization. Clockwise rotation of the trimmers results in increase of the object temperature. Two double-color LEDs are above the corresponding trimmers. They reflect the state of the thermoloops. The absence of any light in THERMO zone indicates the regular temperature regime of a laser diode or a laser case. The green color of a LED informs on active cooling of the corresponding object, that is the outer temperature is higher than the pre-set object temperature. The red color of a LED displays heating (the outer temperature is below the pre-set temperature). The LEDs in the THERMO zone lights red too when the optical head and the electronic unit are both disconnected.

The pushbutton in the THERMO zone is required to indicate the value of the reference resistor, which sets the temperature of a laser diode. The display of the ULDC242 reads its resistance in kilohms at the pressed pushbutton.

The PZT zone includes the knobs of alternative (SCAN) and constant (OFFSET) voltages applied to piezo-elements. The control signal of a high-voltage amplifier is similar to the one of a current source, and the relative phase of two signals allows realizing the synchronous change of the LD current and the laser cavity length. This expands the continuous tuning range of the output laser frequency. To scan piezo the full resource of the high-voltage amplifier can be used providing $\pm 200V$. The maximum PZT tuning is obtained at neutral position of the OFFSET knob. The constant phase difference between the signal of an internal oscillator and a line frequency allows minimizing the influence of line pickup under optical data recording.

The LD zone includes a switch of a laser diode shunt and an indicator of the shunt state. It is recommended to keep a laser diode shorten (the LED does not light) at the moment of electronics switching on and then till the changeover of the LD and case temperature to a steady state. When the LD switch is on (position OPEN, the LED lights green) the shunt changes its value from about 4 Ohm to tens MOhm during a few seconds removing a short circuit and protecting the LD from

the transients. Also the shunt protects a laser diode from a current overload when one of the $\pm 15\text{V}$ voltages breaks down.

The line connector, the input connector for high-frequency (up to 50 kHz) current modulation (MOD), the input connector of an external control signal, the switch of a control signal (EXT-INT), and the output connector of the built-in generator (TRIG) are placed in the upper row of the rear panel. There are the power switch and the optical head connector (DHR-15M) in the lower row. The triangular signal of about $8\text{V}_{\text{p-p}}$ from the TRIG output can be used to control or to synchronize external devices. In order to control the output frequency of the ECDL-8550R by an external signal the EXT-INT switch must be set into the EXT position. In this case the output of the built-in sweep generator is disconnected from the inputs of the current source and the high-voltage amplifier, and the TRIG output duplicate the external signal. The signal from the MOD connector is directly coupled to the current source regardless of position of the EXT-INT switch.

Activation of the ECDL-8550R

1. Connect the cable between the optical and electronic units.
2. Check up the settings of the SWEEP and LEVEL knobs. They have to be in the extreme left position.
3. Turn on the power supply switch on the rear panel of the electronic unit and wait until the LEDs in the THERMO zone stop flashing.
4. Turn on the laser by the LD switch and set the recommended current.

Disabling the ECDL-8550R

1. Set both the AC and the DC to zero (the SWEEP and LEVEL knobs are in the extreme left position).
2. Turn off the laser current by the LD switch.
3. Switch off the power supply.

Frequency tuning and alignment of the ECDL-8550R

The mechanical stability of the ECDL-8550R is high enough to keep the laser output in close vicinity of the particular wavelength (say atomic transition) for weeks, so that the LD current and the PZT voltage remain the only means to tune the laser precisely to this desirable wavelength. However, the degraded characteristics of the ECDL (increasing of the threshold current, output power reducing, tuning range reducing, poor side-mode suppression ratio, amplitude noise increasing) might indicate that realignment of the extended cavity is necessary.

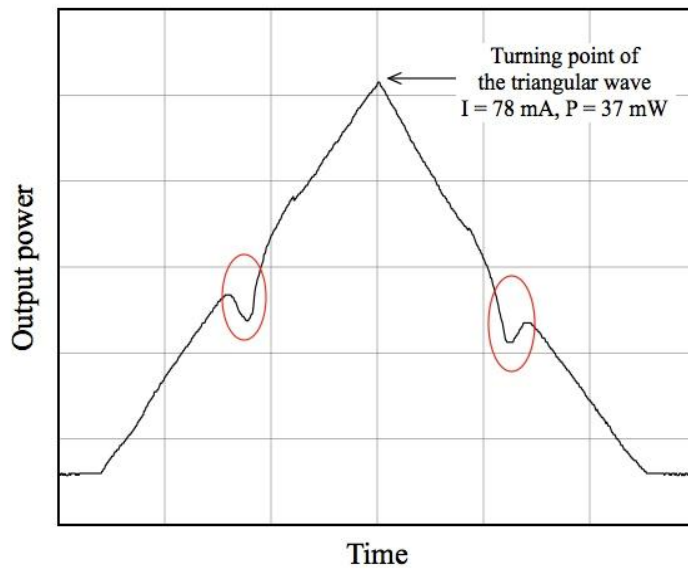

Fig.3. The dependence of the output power on the LD current. The LD current is changed by the symmetrical triangular wave. The red ellipses show the zones of the Cs absorption.

The following experimental data specify the operation of the ECDL-8550R and might serve as references for its alignment. Fig.3 shows the output power of the ECDL-8550R when the internal triangular-wave generator modulates the laser current. The linear change of the laser current induces the nonlinear response of the output power due to mode structure of the laser. This is manifested in the form of mode-hops and slope changes on the power-on-current dependence. The Cs absorption is revealed at some certain zones in Fig.3 (the regions surrounded by the red ellipses). The PZT voltage is set so to make the absorption more evident.

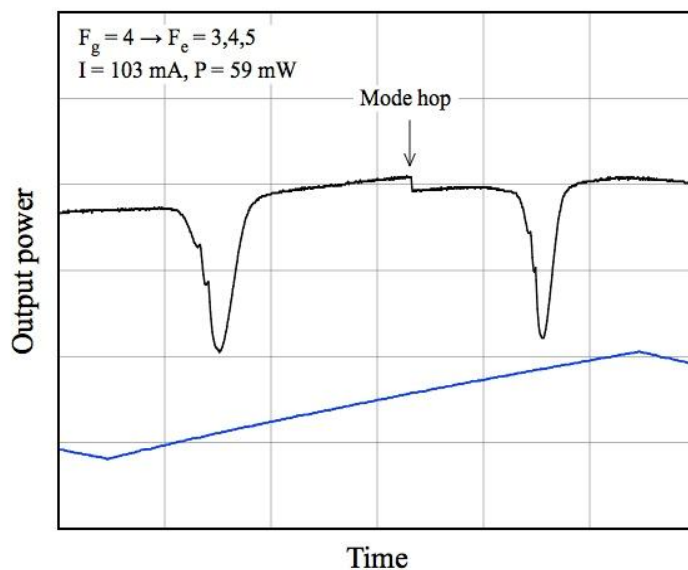

Fig.4. The transmission of the cell containing the vapor of Cs on the PZT voltage sweeping. The LD current is constant.

The transmission of the cell containing the vapor of Cs at the constant current and the gradually changing PZT voltage is shown on Fig.4. Two consecutive extended-cavity mode-hops are visible displaying Doppler-broadened profiles which correspond to $F=4 - F'=3,4,5$ transition. The laser beam reflected from the exit window of the Cs cell together with the direct beam forms the standing wave in the cell. As a result the nonlinear resonances are superimposed on the Doppler absorption resonances.

Full-scale tuning of the ECDL-8550R is achieved by the synchronous sweeping of the piezo voltage and the LD current (Fig.5). The PZT scan is set close to the maximum, while the amplitude of the current scan and the DC levels of the LD current and the PZT voltage are found experimentally to avoid mode-hops inside the full tuning range.

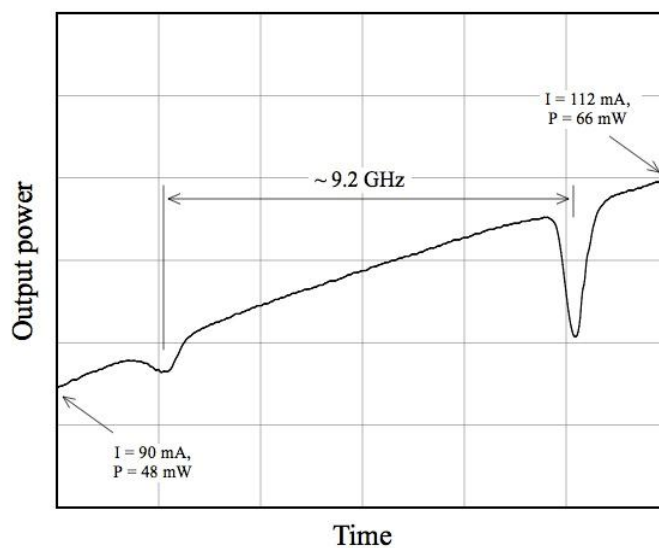

Fig.5. The transmission of the cell containing Cs vapor at the synchronous scan of the piezo and the LD current.

Follow the way below, if the laser realignment is necessary.

- 1) Insert the Γ -shaped lever into the slot of the horizontal axle of the grating.
- 2) Find the direction in which the lever decreases the LD threshold. Gently press the lever up and down for this.
- 3) The clockwise rotation of the lock screw (Fig.1, pos.5) is applied if the motion of the lever down (i.e. the laser beam reflected from the grating goes up) reduces the threshold. The counter clockwise rotation is needed at the up-level position. Use a wrench from the maintenance kit to rotate the lock screw. Typically a few degree rotation of the screw is enough to restore the operation of ECDL-8550R.
- 4) When the minimum of the threshold current is achieved, set if necessary the operation wavelength by tuning the horizontal screw (Fig.1, pos.6) which is accessible even in fully assembled optical unit.

Appendix. The circuits and the layout of the ULDC242.

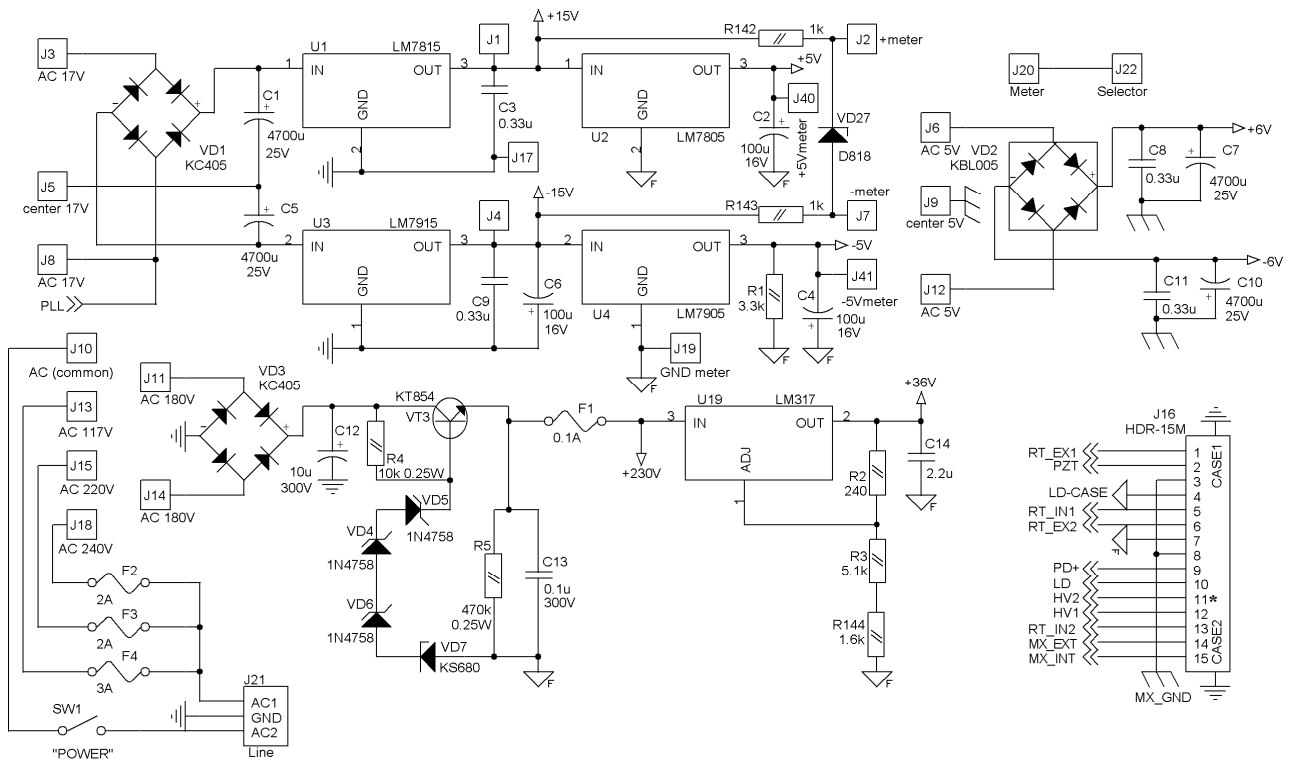

Fig.6. The circuit of the power supply.

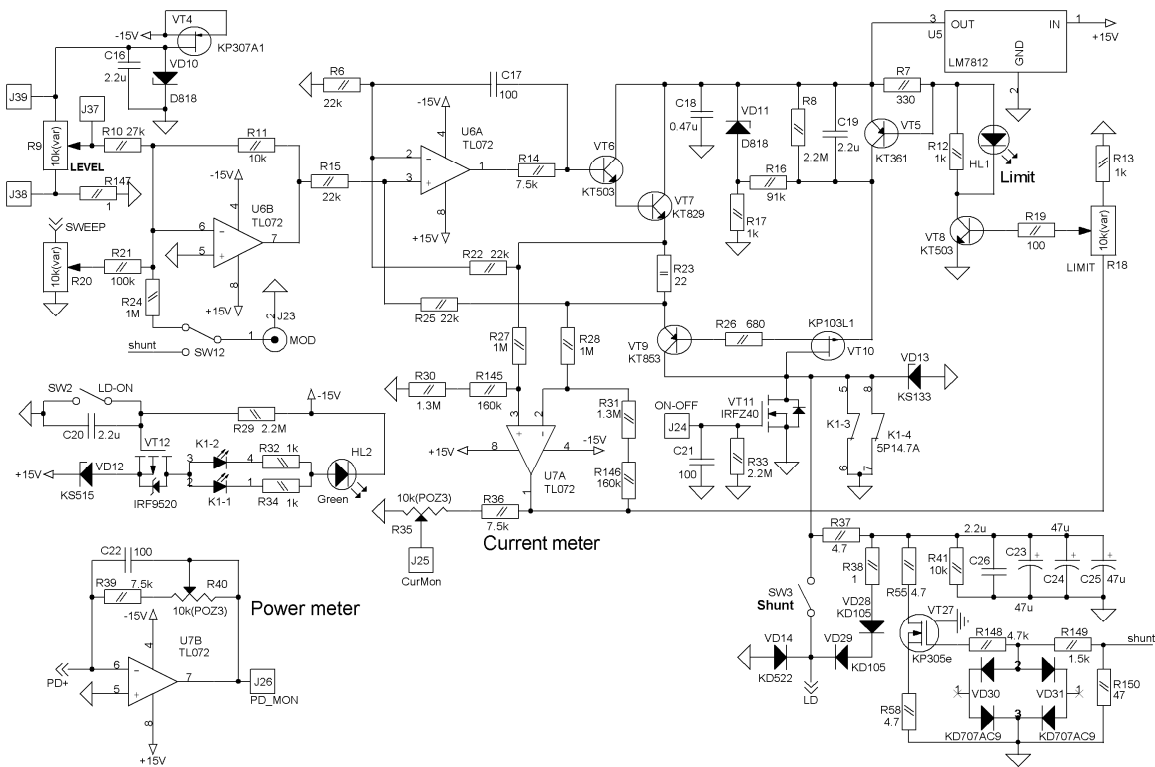

Fig.7. The circuit of the current source.

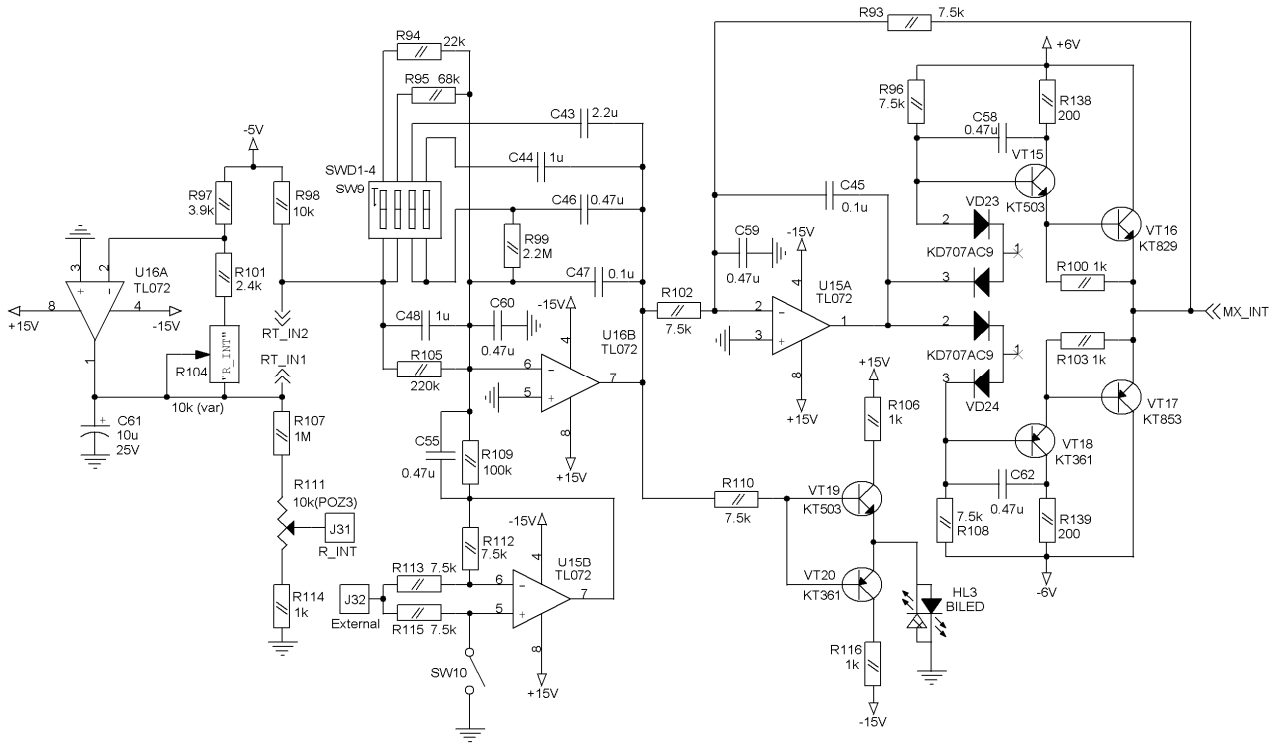

Fig.8. The circuit of the internal temperature controller.

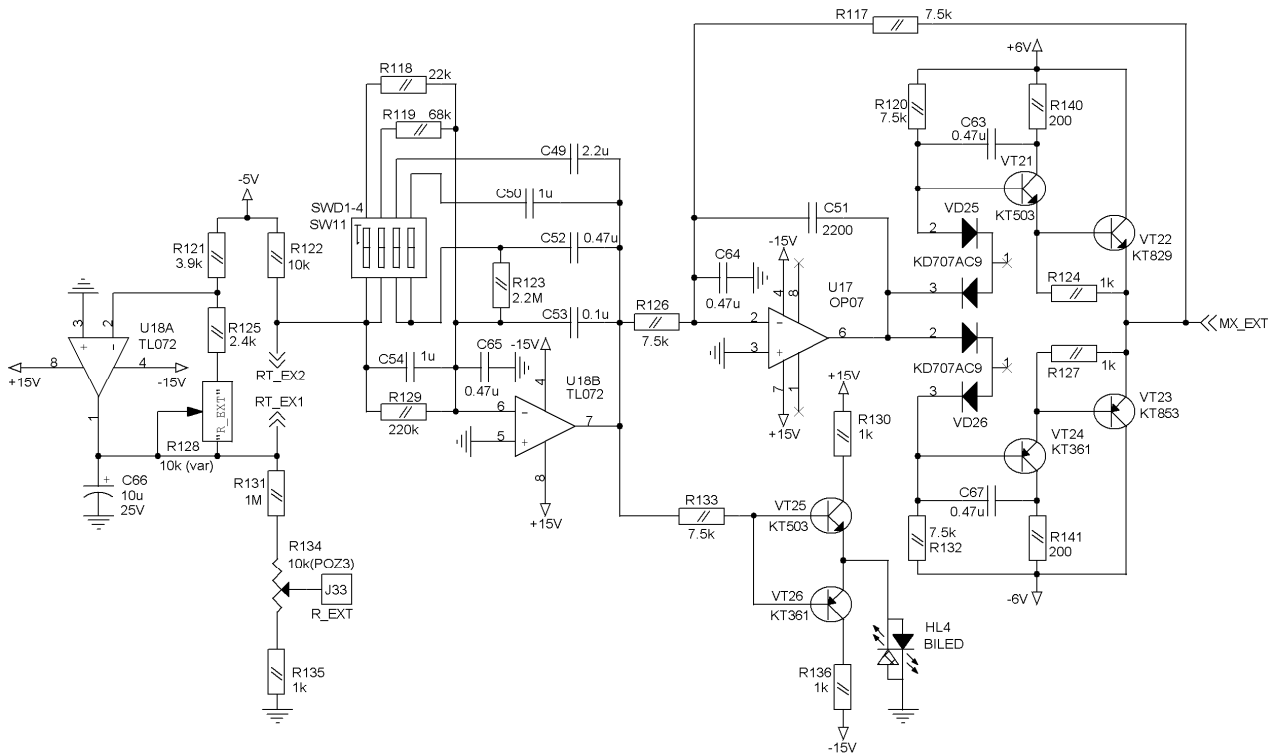

Fig.9. The circuit of the external temperature controller.

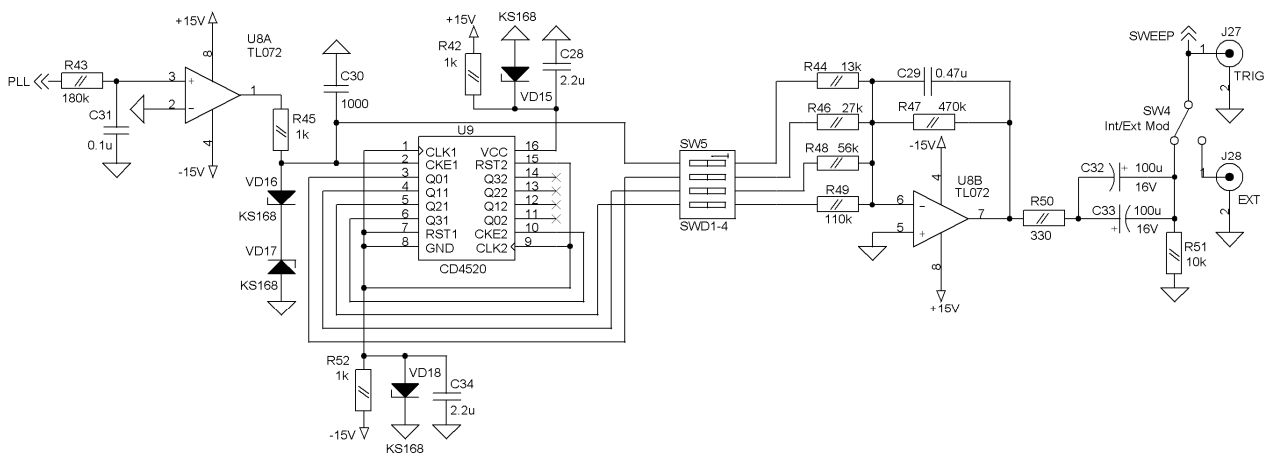

Fig.10. The circuit of the triangular-wave generator.

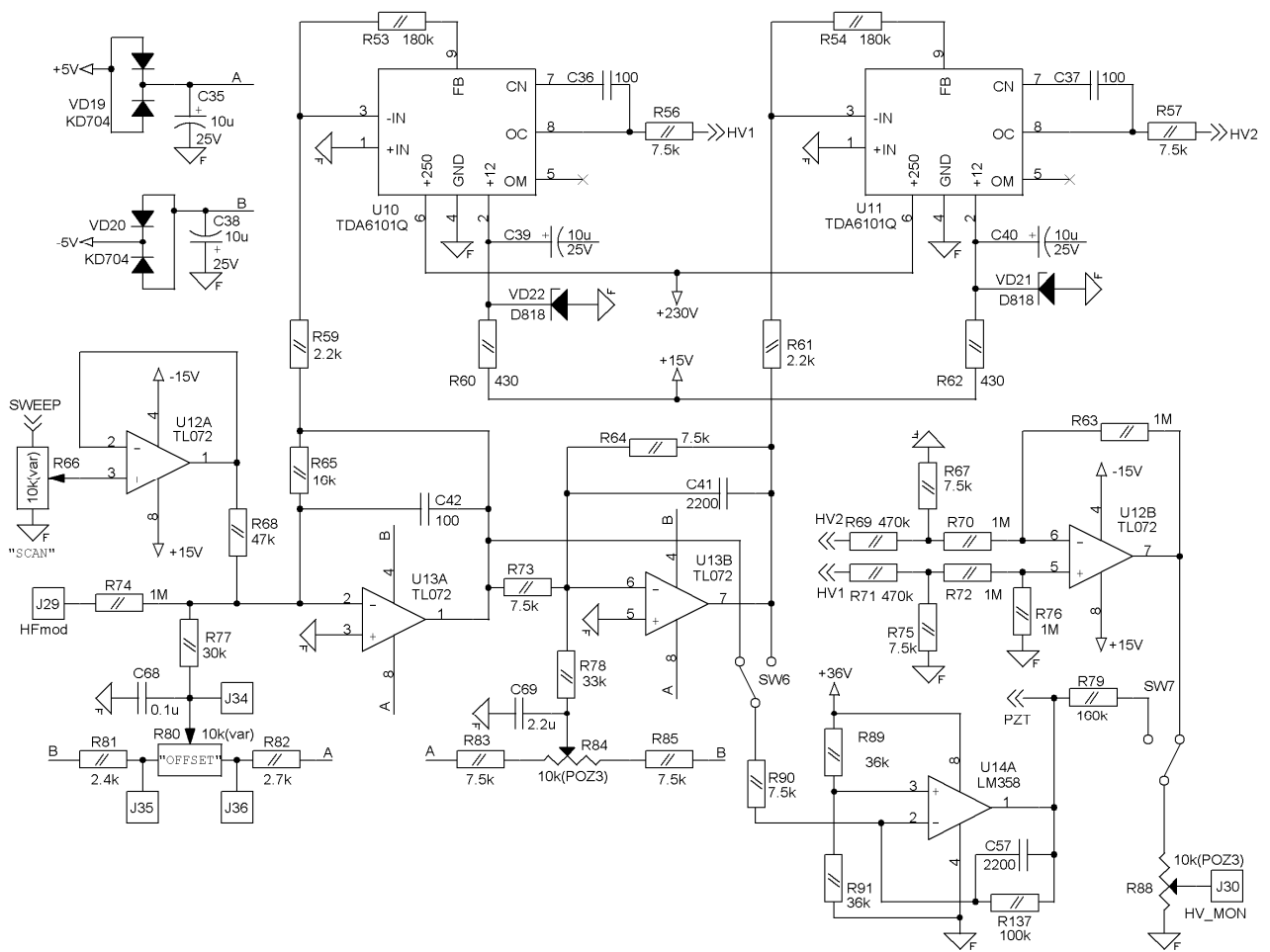

Fig.11. The circuit of the high-voltage amplifier.

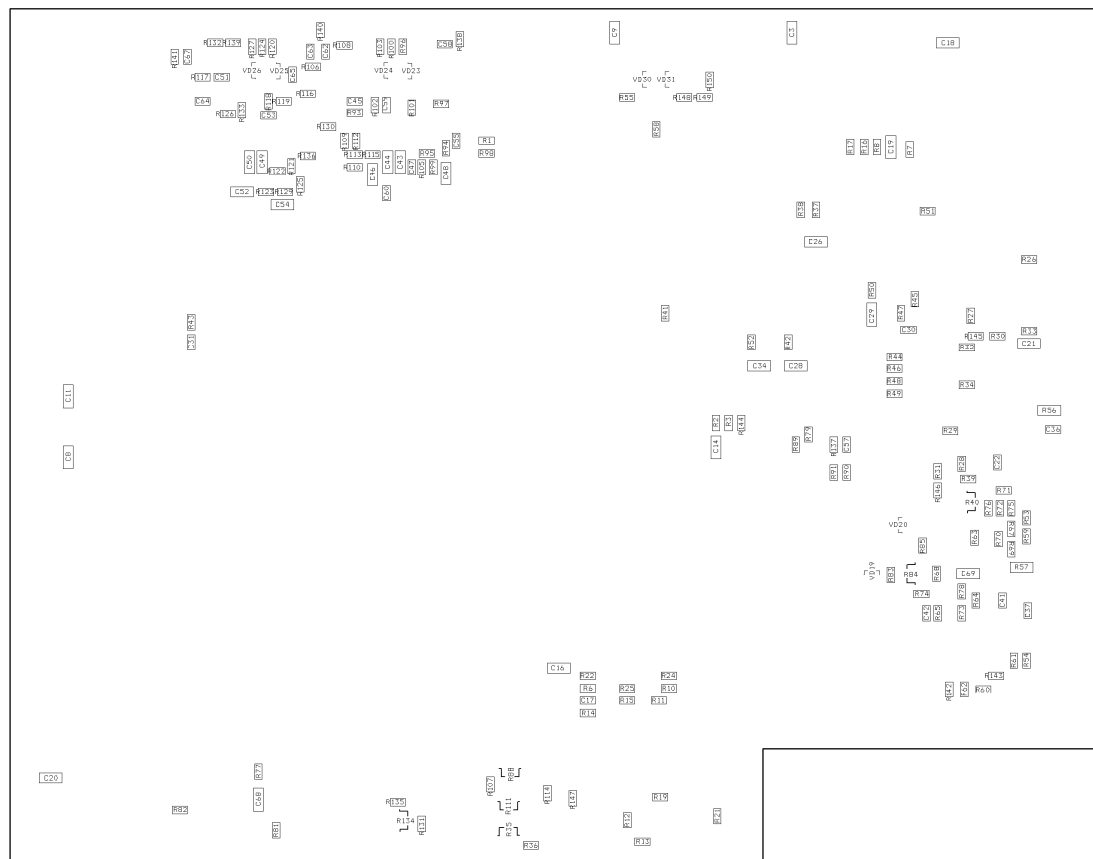
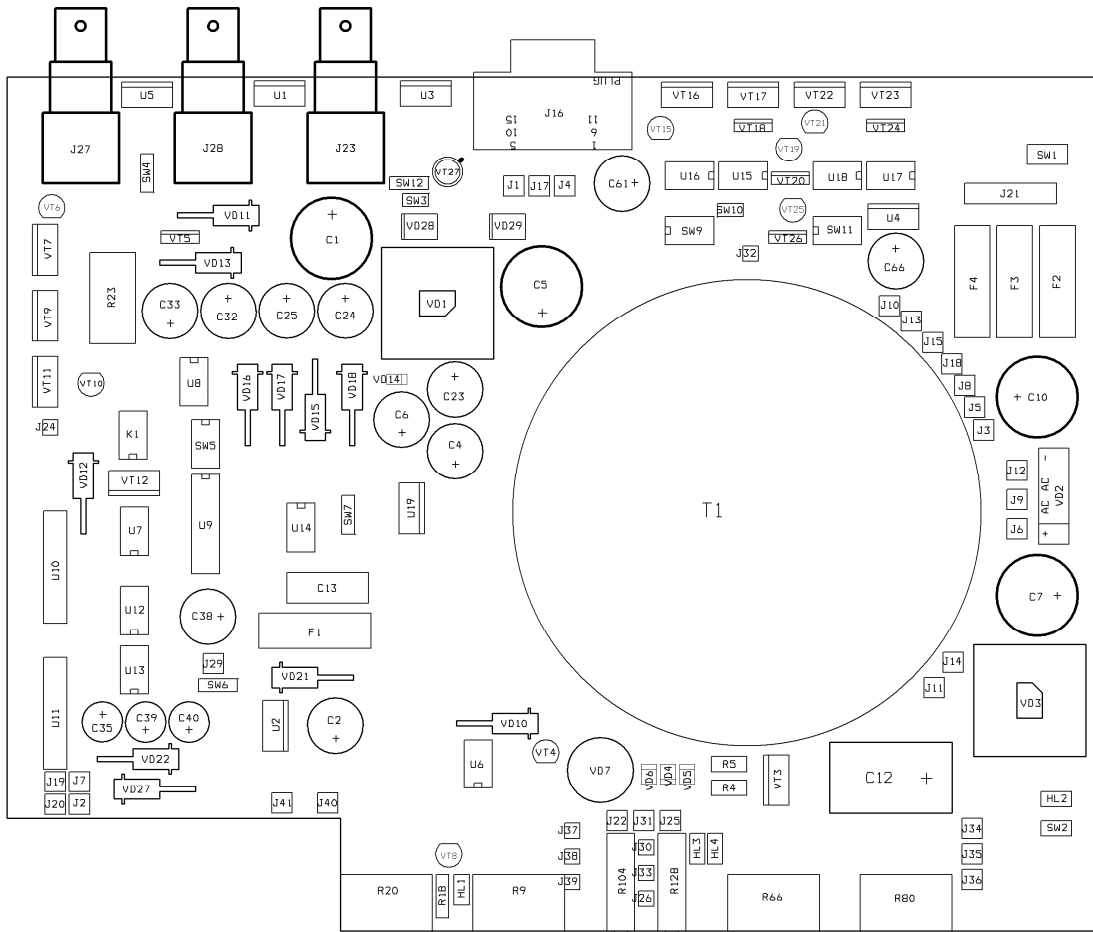

Fig.12. The layout of the ULDC242.

Common recommendations of the ECDL-8550R maintenance

1. Do not try to change the laser beam collimation. In the case of laser diode degradation the module has to be replaced as a whole by a manufacturer.
2. Do not violate the procedures of the laser activation and disabling.
3. Do not reduce the LD temperature below the dew point. The LD temperature can be estimated using the TCR (temperature coefficient of resistance) of the thermistor: $TCR = -4 \text{ \%}/^{\circ}\text{C}$.
4. Use an optical isolator to avoid unwanted reflections back into the laser.
5. Follow **the golden rule**: an ECDL as a part of an experimental setup must be switched on the last and switched off the first.

Specifications

1. Wavelength	852.1 nm
2. Output power @ 104 mA	60 mW
3. Continuous tuning range by PZT only by PZT+LD current	5 GHz 14 GHz
4. Coarse tuning range	$\pm 2 \text{ nm}$
5. Polarization	linear vertical
6. Beam shape	elliptical $5 \times 1.5 \text{ mm}^2$
7. Threshold current	33 mA
8. Operating current	104 mA
9. Thermistor	11.1 kOhm
10. Optical head dimensions	$51 \times 46 \times 35 \text{ mm}^3$
11. Optical head weight	140 g
12. Electronic unit dimensions	$245 \times 200 \times 55 \text{ mm}^3$
13. Electronic unit weight	2 kg